



# SIGN BASE WEIGHT



RubberForm's Sign Base Weight attaches to our Sign Base, providing a total of 150 pounds for extra security in high-wind areas and larger signs. Like our Sign Base, our Sign Base Weight is made in the USA from 100% post-consumer recycled rubber and plastic.

Combined with our Sign Base and recycled aluminum traffic signs, they make an excellent choice for eco-friendly companies.

Use our sign base weight with our sign base parking lots, grocery stores, restaurants, plazas, construction sites, municipalities and more! It is the only solution for anywhere extra weight is needed for portable or semi-permanent signage.

## Key Features

- Aerodynamic design – low center of gravity
- For high-wind areas & larger traffic signs
- Base weight 75 lbs – 150 lbs total with sign base attached
- Made in the USA with 100% American recycled rubber
- Impact and weather resistant – will not warp, chip, crack, spall, or corrode



**Made in the USA**



**100% Recycled Material**



**Increase LEED Score**





# SIGN BASE WEIGHT SPECIFICATIONS

## Models

### RF-SBWT

Sign Base Weight

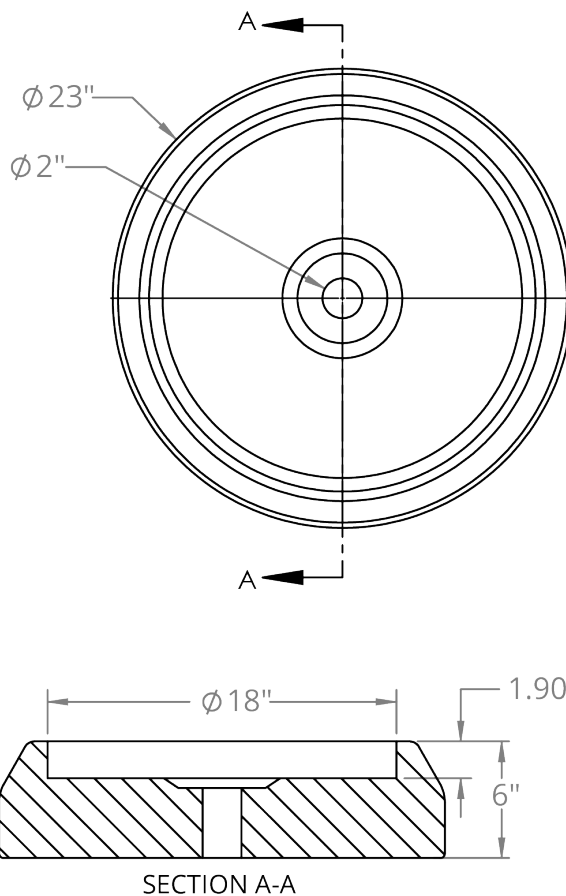

## Specifications

- 75 lbs
- 23"W x 6"H
- Recessed center for the RubberForm Sign Base to sit in

## Hardware Kit

### RF-SBWITHWK

- 4 - 6" RSS Rugged Structural Screws
- 4 - 3/8" x 1-1/12" Fender Washers

### RF-SBMC-LG

- Aluminum hand truck with custom lift plate for 150 lbs sign base system



www.sharpline-solutions.com



(626) 257-8328



sales@sharpline-solutions.com